

Adjusting Meritor 14- and 15-1/2-Inch Diaphragm Spring Clutches

Synchronized and Non-Synchronized Transmissions

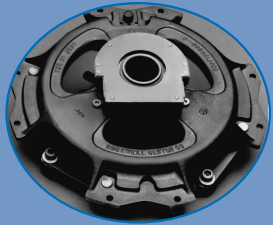

14-Inch

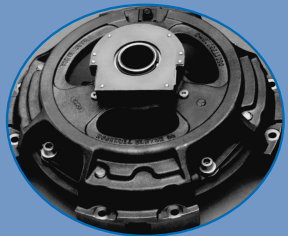

15-1/2-Inch

When You Should Adjust the Clutch

- At clutch removal or installation
- When servicing any clutch linkage component
- Whenever clutch pedal free play travel is less than 0.50-inch (13 mm)

Before You Adjust the Clutch

- The clutch system must be in good condition.
- The clutch linkage should be tight and move freely.
- Check for "false" free travel.
- The release fork should move when you push the clutch pedal.

Clutch Adjustment Tools

0.530-Inch Gauge Tool

Use a 0.530-inch gauge tool, such as Snap-on tool number SP2033, to check the release bearing clearance.

1/8-Inch Gauge Tool

Use a 1/8-inch gauge tool, such as Snap-on tool number SP2034, to check the release fork clearance.

For Complete Clutch Service Information

Refer to Maintenance Manual No. 25A, *Clutches*, for complete instructions on how to adjust Meritor 14- and 15-1/2-inch diaphragm spring clutches. To order this publication, call ArvinMeritor's Customer Service Center at 800-535-5560.



Meritor Heavy Vehicle Systems, LLC
2135 West Maple Road
Troy, MI 48084 USA
800-535-5560
arvinmeritor.com

©Copyright 2000
All Rights Reserved
Revised 10-04
16579/24240
WC-88153

Check Release Bearing Clearance

⚠ WARNING

To prevent serious eye injury, always wear safe eye protection when you perform vehicle maintenance or service.

Synchronized Transmissions

1. Push the clutch pedal to the end of travel several times to ensure the release bearing is fully REARWARD.
2. Remove the bell housing inspection cover.
3. Measure the release bearing clearance. The clearance between the front of the release bearing and the clutch cover must equal 11/16-inch (17 mm). **Figure 1.** Adjust the release bearing clearance if the clearance is outside specification. Refer to the "Adjust Release Bearing Clearance" section below.

Non-Synchronized Transmissions

1. Push the clutch pedal to the end of travel several times to ensure the release bearing is fully REARWARD.
2. Remove the bell housing inspection cover.

NOTE: When checking release bearing clearance on non-synchronized transmissions, the 0.530-inch gauge tool should fit securely between the release bearing and the clutch brake.

3. Measure the release bearing clearance. Use a 0.530-inch gauge tool to check the release bearing clearance. The tool must fit tightly between the release bearing and the clutch brake. Do not force the gauge tool. The release bearing can move FORWARD and will cause an incorrect measurement. **Figure 2.**
4. Adjust release bearing clearance when the gauge tool fits loosely or does not fit. Refer to the "Adjust Release Bearing Clearance" section below.

Adjust Release Bearing Clearance

1. Push the clutch pedal to the end of travel several times to ensure the release bearing is fully REARWARD.
2. Allow the adjusting ring to rotate.

Synchronized Transmissions

Use a block of wood to hold the clutch pedal, or have another person hold the clutch pedal, to provide clearance of at least 1-1/16-inch (27 mm) between the release bearing and the input bearing retainer. Hold the pedal in this position when moving the adjusting ring.

Non-Synchronized Transmissions

Use a block of wood to hold the clutch pedal, or have another person hold the clutch pedal, to provide clearance of at least 1/8-inch (3 mm) between the release bearing and the clutch brake. Hold the pedal in this position when moving the adjusting ring.

⚠ CAUTION

Use the correct size socket on the front pulley to move the flywheel. If the pulley is difficult to turn, use a spanner wrench on the teeth of the flywheel. Do not use the starter to move the flywheel. Damage to components can result.

3. Move the flywheel so that the lock plate becomes visible through the inspection cover.
4. Remove the capscrew and washer on the lock plate. Remove the lock plate. **Figure 3.**
5. Rotate the adjusting ring. Use a screwdriver or an adjusting ring tool as a lever against the notches on the adjusting ring. When you move the adjusting ring one notch, the release bearing will move 0.020-inch (0.50 mm). For a normal adjustment, you will move the adjusting ring from 4 to 8 notches. **Figure 4.**
6. Release the clutch pedal.
7. Check release bearing clearance. Refer to the "Check Release Bearing Clearance" section above. If the clearance is outside specification, adjust the clearance.
8. Install the lock plate and capscrew. Tighten the capscrews to 25-30 lb-ft (34-40 N·m). ⚠
9. Check release fork clearance to determine if you must adjust the clutch linkage. Refer to the "Check Release Fork Clearance" section below.

Check Release Fork Clearance

NOTE: To prevent the release bearing from moving on non-synchronized transmissions, insert a 0.530-inch gauge tool between the release bearing and the clutch brake.

1. Release the clutch pedal.
2. Insert the 1/8-inch gauge tool between the tips of the release fork and release bearing bosses. **Figure 5.**
3. Check both sides. If the tool fits too loosely or does not fit, you must adjust the clutch linkage according to the vehicle manufacturer's procedure and specifications.

⚠ CAUTION

Always install the bell housing inspection cover. If an inspection cover is missing during operation, dirt and contaminants can enter the bell housing. Damage to the clutch can result.

4. Install the bell housing inspection cover.

Figure 1

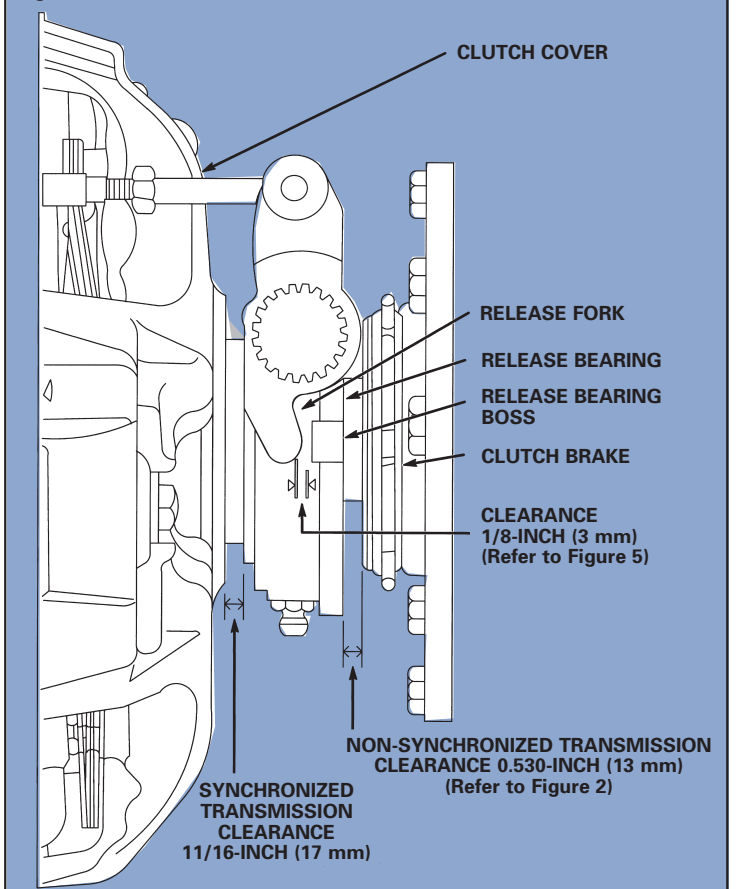

Figure 2

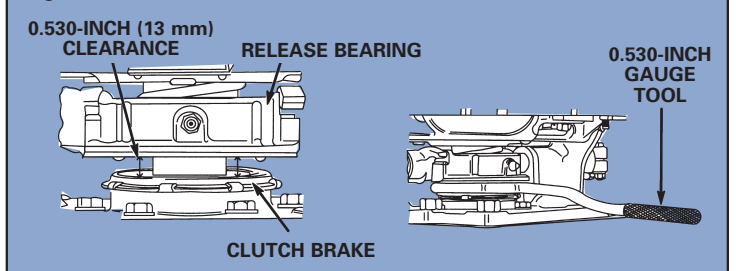

Figure 3

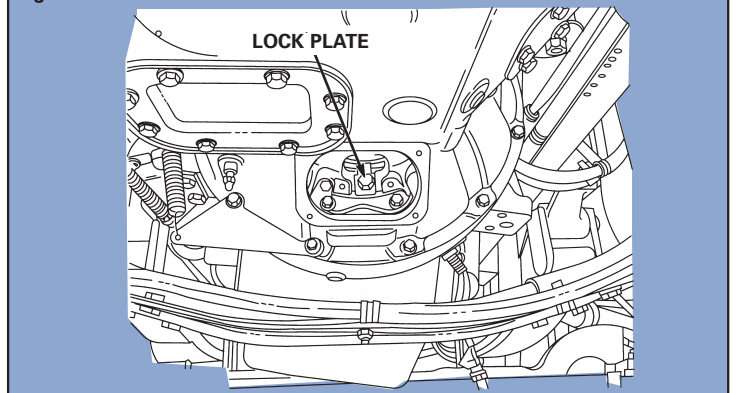

Figure 4

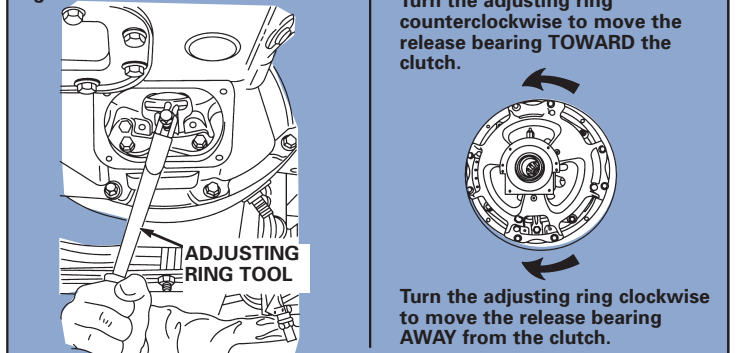

Figure 5

